Thickener

Our company has researched and developed sludge treatment system over five years, which has reached the international leading level of waste water purification equipment and can solve some serious problems, such as waste water of sand, not recycling and reusing, discharging waste water random, destroying seriously river, mountains, cities and villages system. The product can be combined into production line with production machinery equipment, such as sand washing machine, dewatering screen, tailing dewatering screen, sand recycling machine and so on, which is widely used in sand and stone aggregate plant, precious metal dressing plant, ceramics, glass and other industries.



● How It Works – sludge treatment system:

Deep cone thickener is a machine that based on gravity and sedimentation which makes solid-liquid separate from each other. The concentration of pulp waste water could be enhanced from 60%~ 70% to 2% ~ 15% by the machine, the clear water is overflow from the upper part of the thickener , so as to achieve the purpose of sewage purification and solid-liquid separation.

General Operating Process

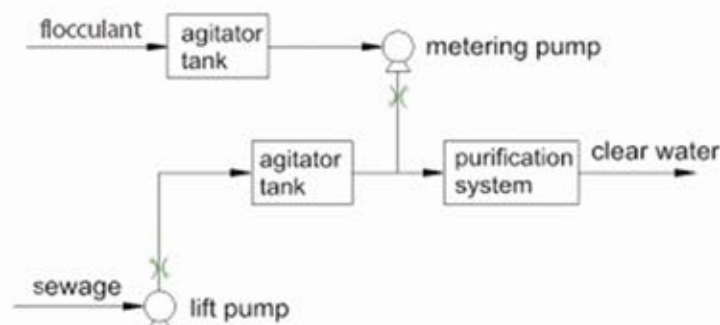

● Technology Advantages:

1. Automatic cleaning, automatic discharge slurry, solve manual operation;
2. Made of qualified carbon steel (or stainless steel, epoxy glass fiber reinforced plastic, etc.), with good strength and corrosion resistance;
3. Low flocculant using cost, big capacity, high efficiency, stable performance;
4. Small volume, small floor space, easy installation;
5. The purified water can totally reach to national standard of discharge and can be recycled.



● Specifications:

Model	Feed concentration(%)	Capacity (t/h)	Water recycling(%)	Weight (kg)	Overall dimensions LxWxH (mm)
S-2600	≤10	40	70-80	4000	φ3000X5700
S-3000	≤10	70	70-80	5500	φ3400X6000
S-3300	≤10	100	70-80	7500	φ3600X6400

● Process case:

sludge treatment system

